



# **GAS 26L OUTDOOR NG/LP GAS**

**GAS TANKLESS WATER HEATER**

**INSTRUCTIONAL  
MANUAL**



Keep this manual with you after your unit has been installed, you may need it for further technical information.



Congratulations! You've just purchased a new Marey Gas Powered tankless water heater and will soon begin to enjoy the benefits of "going tankless."

The availability of instant hot water, combined with the unit's outstanding energy efficiency and space saving design, will quickly prove you that you've made the best decision for meeting your home's hot water needs.

Take the time to thoroughly read and understand this safety and installation manual in its entirety before you attempt to install your new gas Powered tankless water heater, as it contains important safety tips and instructions.

Please carefully read all instructions and warnings. Should you have any questions, please visit [www.marey.com](http://www.marey.com) for installation videos and FAQ. Please keep this manual for future reference.

**WARNING:** This unit should be installed by a certified professional in accordance with all local building and plumbing codes. Under no circumstances should you attempt to install, repair, or disassemble the Marey Gas Powered water heater without first shutting off any gas supplied to the unit.





# INDEX

|                                |           |
|--------------------------------|-----------|
| <b>IMPORTANT NOTES</b>         | <b>04</b> |
| <b>PERFORMANCE FEATURES</b>    | <b>06</b> |
| <b>INTRODUCTION</b>            | <b>08</b> |
| <b>INSTALLATION</b>            | <b>11</b> |
| <b>REMOTE CONTROLLER</b>       | <b>21</b> |
| <b>INITIAL OPERATION</b>       | <b>23</b> |
| <b>NORMAL OPERATION</b>        | <b>24</b> |
| <b>MAINTENANCE AND SERVICE</b> | <b>25</b> |
| <b>PACKING LIST</b>            | <b>30</b> |



# 1. IMPORTANT NOTES

- This manual has been prepared for the installation and use of the equipment.
- Please keep it in a safe place for future reference.

## 1.1 INSTALLATION NOTES

The installation must be done in accordance with the information supplied in this manual. All other relevant national, state and local regulations must also be adhered to including (but are not limited to):

- National Fuel Gas Code:
  - American Standard ANSI Z223.1/NFPA 54.
  - Canadian Standard CSA B149.
- The Manufactured Home Construction and Safety Standard:
  - American Standard, Title 24 CFR, Part 3280.
  - Canadian Standard CSA 2240 MH.
- National Electrical Code:
  - American Standard ANSI/NFPA 70.
  - Canadian Standard CSA C22.
- American National Standard / Canadian Standards Association Standard for Gas Water Heaters:
  - ANSI Z21.10.3-CSA.
- Local, Water, Gas, Electrical and Plumbing Authority Regulations.
- Municipal Building Codes including local OH&S requirements.

## 1.2 SERVICE NOTES

Maintenance and trouble-shooting must be done in accordance with these instructions and the applicable regulations listed above.

## 1.3 GAS WATER HEATER MAINTENANCE

It is recommended to flush and maintain the gas water heater for  $\geq 1$  times a year. Please contact your local dealer for maintenance. Do not disassemble the gas water heater without permission.



## WARNING

**SERVICE SHALL BE CARRIED OUT ONLY BY AUTHORIZED PERSONNEL  
AND THE APPLIANCE SHALL NOT BE MODIFIED  
(for example, a licensed plumber or gas technician).**

## 1.4 PLUMBING NOTES

- **PLEASE NOTE** GA260 model is supplied factory pre-set at Nominal 70°C maximum outlet watertemperature to comply.
- The GA260 unit **REQUIRES** a temperature control device to be installed.
- Please follow all the instructions in the Installation Guide and the following additional instructions for the water heater outlet connection:

1. When connecting the hot water supply to the fixtures of the property a minimum of two (2) metres of pipework must be used between the outlet of the water heater and the first tap / outlet. (As shown in the picture below).
2. The hot water line should be insulated with Armaflex or similar pipe insulation.
3. When the installation is completed the temperature is to be tested at the taps to confirm the water temperature does not exceed the required 50°C setting.
4. Water pipe size is nominal 15mm from hot water outlet to the first tap / outlet.
5. Gas pipe size is nominal 20mm.

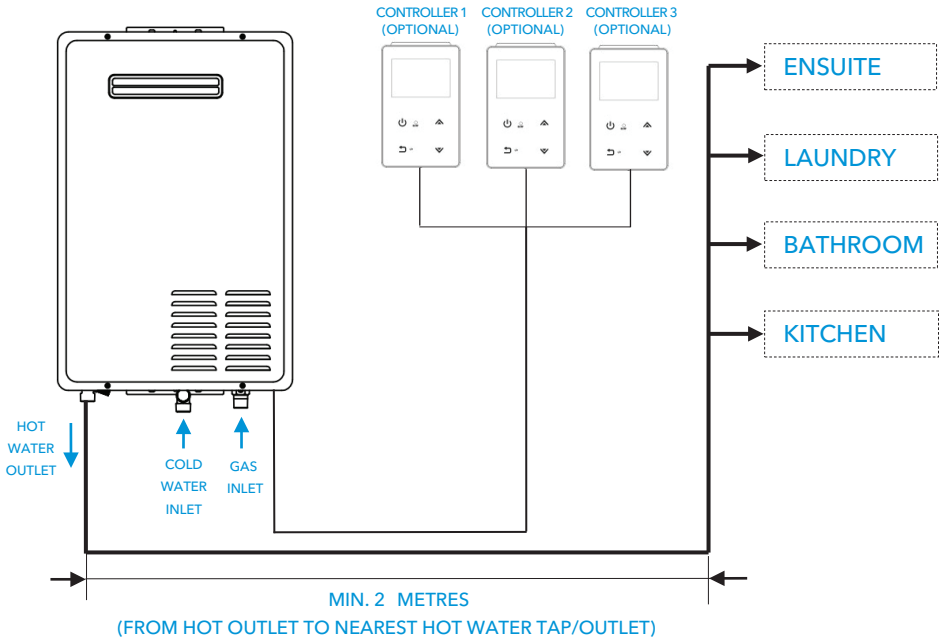



## IMPORTANT WARNINGS ABOUT HOT WATER



### WARNING ABOUT HOT WATER

- Heated water can be dangerous, especially for young children and the vulnerable.
- Water temperatures above 50°C can cause severe burns instantly and may even result in death.
- Those most at risk are children, disabled and elderly.
- Hot water at 65°C can severely burn a child in less than half a second. At 50°C it takes five minutes.



### ALWAYS...

- Test the temperature of the water with your elbow before placing your child in the bath, also carefully feel water before bathing or showering yourself.
  - Supervise children whenever they are in the bathroom.
- Make sure that the hot water tap is turned off tightly.

### CONSIDER...

- Installing child proof tap covers or child resistant taps (both approaches will prevent a small hand from being able to turn on the tap).
- Setting your appliance at a maximum temperature of 50°C.

### NEVER...

- Leave a toddler in the care of another child. They may not understand the need to have the water temperature set at a safe level.



## 2. PERFORMANCE FEATURES

- This product is a forced type gas water heater. When the gas water heater is powered on, the expended gas will be forced to exhaust out with the help of an internal draught fan.
- Rain-proof outdoor gas water heater: when the gas water heater is installed outside, its rain-proof design helps to stop the rain dropping into the gas water heater.
- The gas water heater inhales air from outside to burn and exhaust the gas waste to outside.
- User can operate the gas water heater through a remote control device, it is safe and reliable.
- Digital constant temperature system: microcomputer control system is a “computer” of the gas water heater to control and coordinate the water, electricity, and gas of the gas water heater to make sure that the outlet water temperature is stable and meets shower requirements.
- Low start up water pressure: low water pressure to start up and suitable to use widely.
- Flame-out protection: when working, if the gas water heater flames out suddenly, it will cut off the gas automatically to make sure no gas leakage occurs.

- Continuously variable wind resistance feature: when the chimney or the gas exhaustion is blocked, the built-in microcomputer system will detect and enhance the revolving speed of the fan to eliminate the noxious gas. When the revolving speed is up to the limited speed, the microcomputer system will send out an order to cut off gas and flame so as to protect the gas water heater.
- Water-gas valve control: when the city water supply is cut off or the water outlet valve is shut down, the gas water heater will stop working and power off.
- Over-pressure protection: when the water pressure supply is too high, the safety valve in the gas water heater will release water pressure automatically to protect the gas water heater from damage.



## WARNING

The water heater has an automatic drainage function. When the water inlet pressure of the water heater exceeds 1.0MPa~1.2MPa, the water heater will automatically drain. Please do not place objects around the water heater to avoid damage caused by water immersion of the water heater. When the water heater automatically drains the water, it indicates that the water system pressure is too high. After the pressure is reduced or the water valve is closed, confirm that the pressure meets the requirements for using the water heater.



## NOTES

- The appliance will operate at reduced performance below 340 kPa water pressure.
- For information relating to burner test point pressures and injector sizes refer to the name plate located on the right hand side of the case for each model. *(Please refer to p.11)*
- For information relating to overall dimensions and connection points refer to diagrams. *(Please refer to p.9,16)*
- Installing in areas over 1500 m above sea level will reduce performance.

## 3. INTRODUCTION

- This manual provides information necessary for the installation, operation, and maintenance of the water heater.
- The model description is listed on the name plate which is attached to the right side of the case of the water heater. (Please refer to p.12)
- Please read all installation instructions completely before installing this product.
- The Water Heater is an instantaneous water heater designed to efficiently supply endless hot water on demand.

### THE PRINCIPLE OF THE WATER HEATER IS SHOWN BELOW:

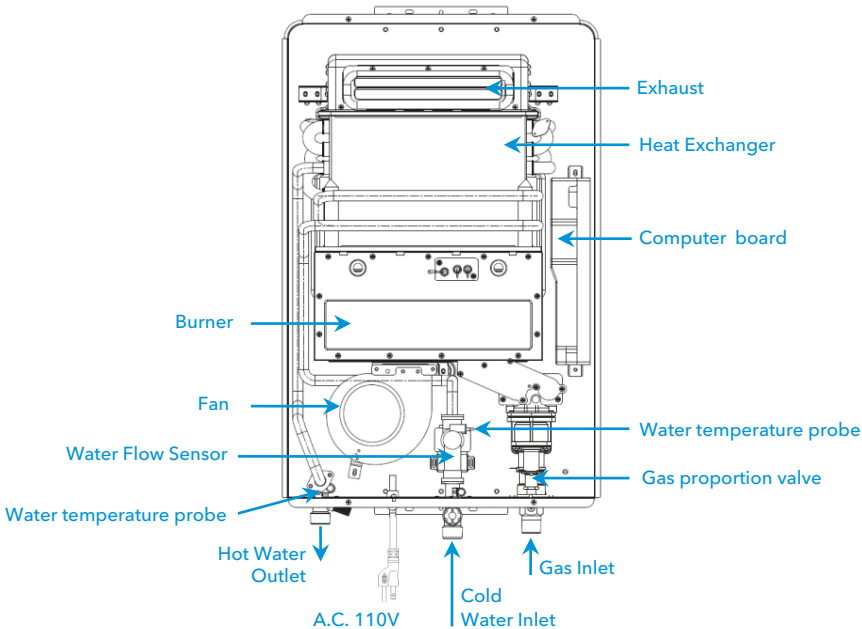

### OPERATION PROCESS OF GAS WATER HEATER:

- ①. A hot water tap is turned on.
- ②. Water enters the water heater via the cold water inlet.
- ③. The water flow sensor detects the water flow.
- ④. The computer automatically ignites the burner.
- ⑤. Water circulates through the heat exchanger and is heated
- ⑥. The computer will modulate the gas supply valve and water flow to produce the right amount of hot water at the correct temperature.
- ⑦. When the tap is turned off, the unit shuts down.



### 3.1 DIMENSIONS AND CONNECTION POINTS

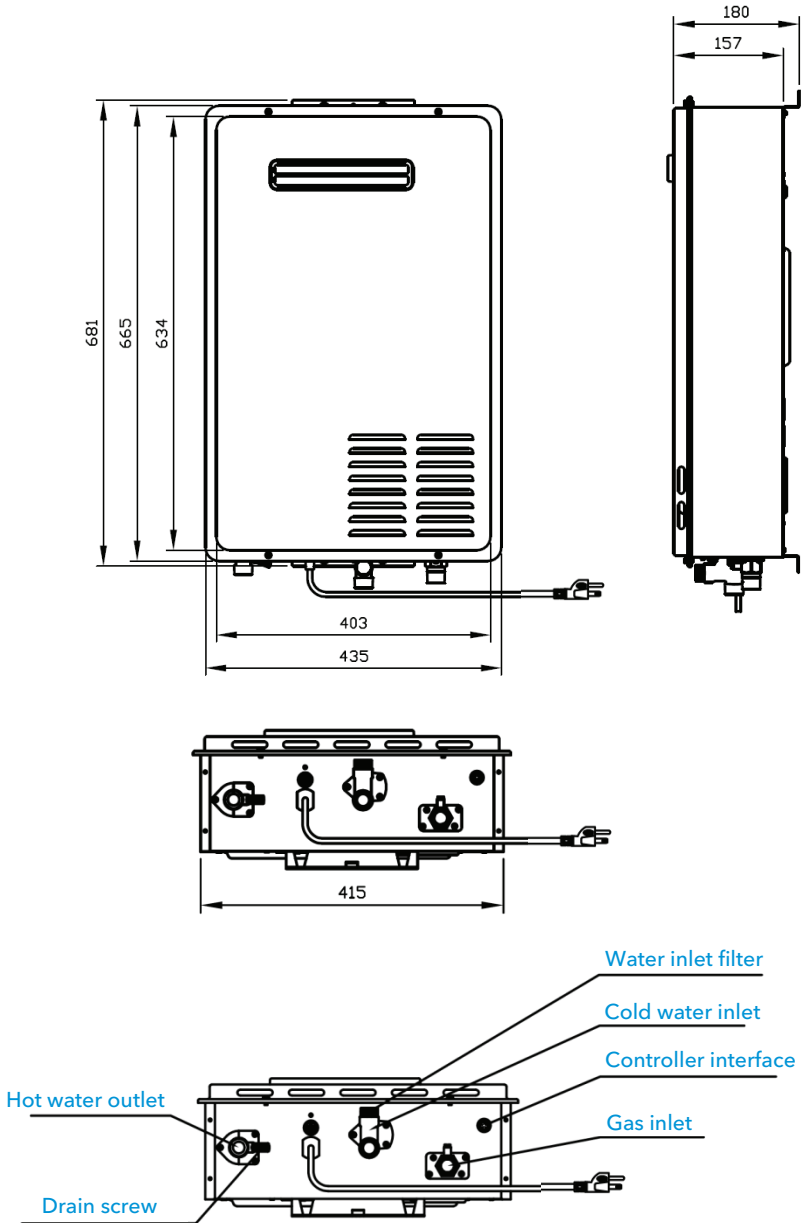

## 3.2 SAFETY GUIDELINES

Ensure the following warnings and instructions are read and understood before commencing installation.



### WARNING

- Installation and service must be performed by a licensed professional (for example, a licensed plumber).
- The licensed professional is responsible for the correct installation of the water heater and for compliance with all relevant national, state and local regulations.
- The water heater must be installed outdoors only. Do not install water heater indoors.
- Not to be used as a pool heater.

## 3.3 GENERAL GUIDELINES

- Carefully plan where you intend to install the water heater.
- Please ensure:
  - The water heater has adequate space for natural ventilation;
  - Is located where water leakage will not damage surrounding areas;
  - Has all transit protection/packaging removed;
- Check the name plate and gas type label for the correct gas type, gas pressure, water pressure and electric rating; If this unit does not match operating condition, do not install and consult with your supplier.
- If any problem should occur, turn off the gas, all hot water taps and call a licensed professional.



### WARNING

- Water temperatures above 50°C can cause severe burns or death from scalding.
- Children, the disabled and the elderly are at a high risk of being injured. Feel the water temperature before bathing or showering. Do not leave children, disabled persons, or the elderly unsupervised.
- This appliance is not intended for use by persons (including children) with reduced physical, sensory or mental capabilities, or lack of experience and knowledge, unless they have been given supervision or instruction concerning use of the appliance by a person responsible for their safety.
- Children should be supervised to ensure that they do not play with the appliance.
- If the supply cord is damaged, it must be replaced by the manufacturer, its service agent or similarly qualified persons in order to avoid a hazard.



## PROHIBITED

- Do not store or use gasoline or other flammables, vapors, or liquids in the vicinity of this appliance. Vapors from flammable liquids will explode and catch fire causing death or severe burns.
- Do not reverse the water and/or gas connections as this will damage the gas valves and can cause severe injury or death. Follow the diagram when installing your water heater *(Please refer to p.8)*.
- Do not use this appliance if any part has been in contact with or been immersed in water.
- Immediately call a licensed professional to inspect and/or service the unit if necessary.
- Do not disconnect the electrical supply if the ambient temperature will drop below freezing.
- The Freeze Prevention System only works if the unit has electrical power. The warranty will not be covered if the heat exchanger is damaged due to freezing. Refer to the section on the Freeze Prevention System for more information *(Please refer to p.25)*.



## 4. INSTALLATION

### 4.1 SPECIFICATIONS

#### TECHNICAL DATA AND DIMENSIONS

| Model name                      |                    | 26HW70 A             |        |
|---------------------------------|--------------------|----------------------|--------|
| Gas category                    |                    | NG                   | ULPG   |
| Nominal Gas Consumption         | BTU/HR             | 180000               | 180000 |
| Nominal minimum gas consumption | BTU/HR             | 40000                | 40000  |
| Test Point Pressure             | kPa                | 1.74                 | 2.74   |
| Nominal burner pressure         | kPa                | 1.13                 | 1.38   |
| Water Pressure Maximum          | kPa                | 750                  |        |
| Water Pressure Minimum          | kPa                | 10                   |        |
| Number of burners               | Pcs                | 1                    | 1      |
| Number Of Injectors             | Pcs                | 18                   | 18     |
| Injector Diameter               | mm                 | 1.45                 | 1.1    |
| Burner Control Segment          | Pcs                | 6, 12, 18            |        |
| Electrical rating               | W                  | 44                   | 44     |
| Heat output                     | kW                 | 52.8                 | 52.8   |
| Water heating capacity          | L/min at 25°C Rise | 26                   | 26     |
| Height                          | mm                 | 635                  |        |
| Width                           | mm                 | 415                  |        |
| Depth                           | mm                 | 157                  |        |
| Net Weight                      | Kg                 | 18.9                 |        |
| Overheating Cut -off            | °C                 | 80                   |        |
| Electricity supply              |                    | 110Va.c, 60Hz        |        |
| Ignition                        |                    | Direct without pilot |        |
| Gas inlet connection            |                    | G3/4                 |        |
| Water connection                |                    | G3/4                 |        |

The water heater requires careful and correct installation to ensure safe and efficient operation. This manual must be followed. Please read the “SAFETY GUIDELINES” and the “IMPORTANT-NOTES” sections at the beginning of this manual.

## 4.2 CONFIRM THE APPLIANCE SUITABILITY

Check the gas type label and the name plate for the correct gas type, gas pressure, water pressure and electrical rating for your application. Do not install the unit if these requirements are not met.

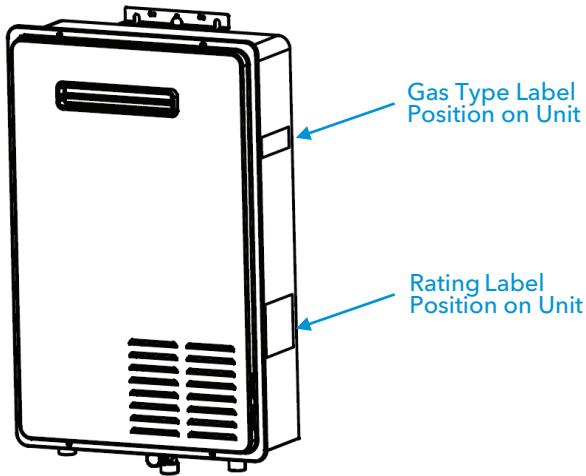

## WARNING

- This equipment is not suitable for pool or spa heating.
- Water hardness may affect the water heater performance. It is important that the water heater is installed in water conditions that are suitable for long term operation.
- This is a water heating apparatus only and the delivered water quality is dependent upon the quality of water supplied to this system.
- The connection, attachment, integration or general association of other equipment or parts not specified by the water heater which either directly or indirectly affect the operation or performance of this equipment could void the warranty.
- The manifold pressure is preset at the factory. It is computer controlled and should not need adjustment.
- It should be as close as practical to the hot water outlets to minimise heat loss and cost.
- The water heater does not require a fireproof back plate if installed on a timber wall.
- Special conditions which should be avoid, e.g. marine environment, high humidity conditions (more than 95%RH), to ensure optimum performance.

## 4.3 SELECTING SUITABLE LOCATION FOR INSTALLATION

Carefully read this section before installation and selecting the location for installing the water heater. The following precautions should be considered.



### WARNING

- This is a water heating apparatus only and the delivered water quality is dependent upon the quality of water supplied to this system.
- Although the water heater is designed to operate with minimal noise level, you should not install the unit on a wall adjacent to a bedroom, or a room that is intended for quiet study or meditation, etc.
- Locate your heater close to a drain where leakage will not do damage to surrounding areas.
- As with any water heating appliance, the potential for leakage at some time in the life of the product does exist.



### WARNING

- Take proper care to warn occupants of the building and the public of any injury that may occur from falling tools, open trenches, water connections or any other general hazard.
- Make sure the water heater will have sufficient room to expel combustion air and operate with natural ventilation.
- Keep the area around the water heater clean. Particles may clog the air vent, reduce fan function, or cause improper combustion.
- Locate the unit for easy access and maintain clearance for service and maintenance. Install the unit so that it can be connected or removed easily.
- The water heater must be installed outdoors only. Do not install the water heater indoors.
- Not to be used as a swimming pool heater.
- Do not locate your water heater in a pit or any location where gas and water can accumulate.
- Please check the proximity of gas & electrical connections so as not to create a hazard and avoid access problems for other services.
- It must be located in accordance with the requirements clearances from eaves, windows, vents etc. –And see the diagram on the p.12~13. for more surrounding construction material requirement.
- Do not place flammable or explosive materials within one meter of the water heater to avoid fires;
- This relates to the physical separation distance specification where multiple appliances are employed. That equates to a minimum 150mm horizontal flue separation distance allowing appliances to be placed side by side in the same vertical plane
- Most load bearing walls such as brick, brick/veneer, weatherboard and stud-frames are suitable locations.
- Securely fasten the unit to the wall with screws or bolts in the top and bottom brackets.
- And see the diagram on the p.12~13. for more surrounding construction material requirement.

## 4.4 CLEARANCES FOR OUTDOOR HEATER LOCATIONS

- Clearance in accordance with local installation codes and the requirements of the gas supplier.

- A vent shall not terminate directly above a sidewalk or paved driveway that is located between two single family dwellings and serves both dwellings.

- Permitted only if veranda, porch, deck, or balcony is fully open on a minimum of two sides beneath the floor.

- This water heater is strictly forbidden to be installed indoors and in the bathroom.

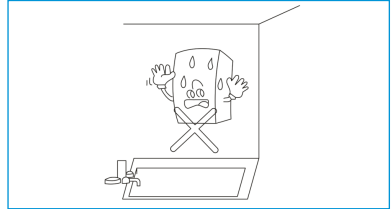

- The water heater shall not be installed under the exhaust fan of the exhaust fan or the range hood.

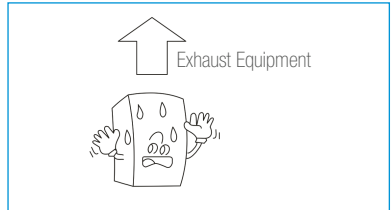

- There shall be no other gas appliances near the installation of the water heater, and there shall be no flammable gases, liquids, etc. around it.



- Installation of outdoor water heaters should avoid the impact of other people's lives due to exhaust and noise.

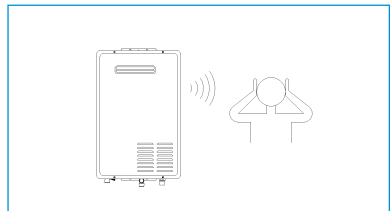

- The water heater must be installed in a well ventilated area (eg. open balcony, patio).

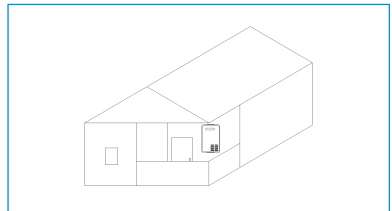

- The distance between the water heater and the surrounding wall, unit: mm.

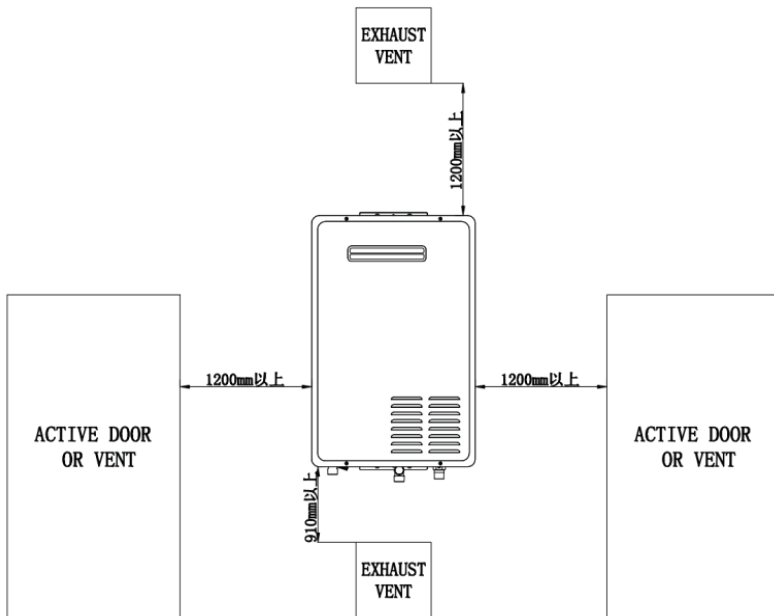
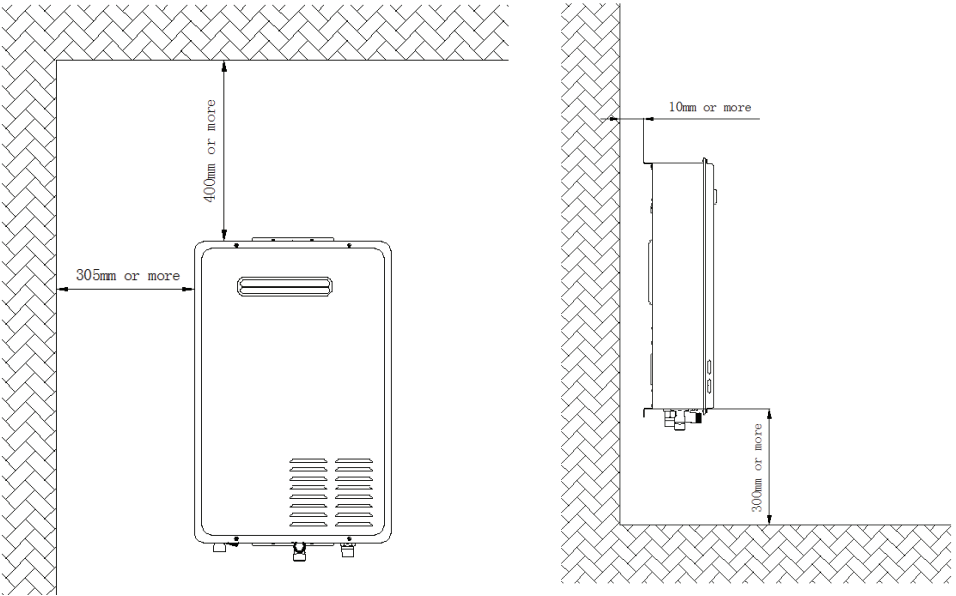

## 4.5 WATER HEATER INSTALLATION

①. According to the requirements of the figure and the size of the water heater, mark the wall with a dash mark, then drill three holes with a diameter of  $\phi 8\text{mm}$  and a depth of 60mm, respectively insert three M6 $\times$ 50mm expansion screws into the hole and tight the expansion screws with a wrench.

②. Hang up the water heater, screw on the M6nut, and fix the water heater to the wall;

③. The installation of the water heater must be correct, otherwise it will affect the normal use of the water heater;

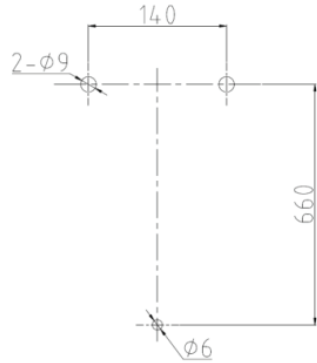

## 4.6 GAS CONNECTION

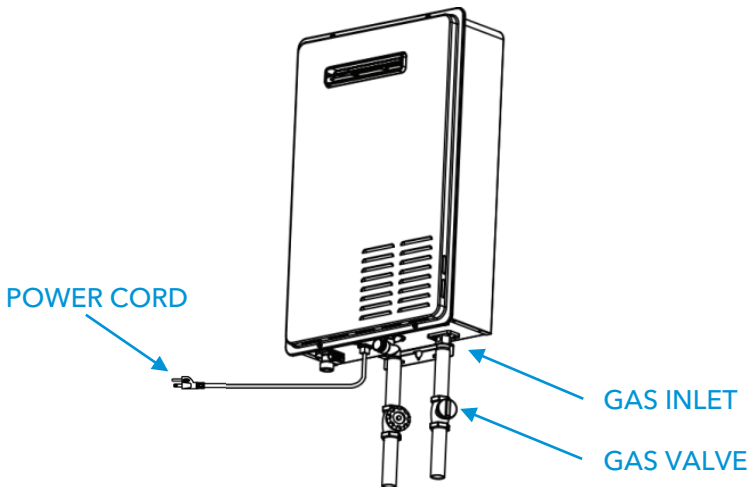



## 4.7 SIZING AND CONNECTION SUITABILITY

- Check the gas type label to make sure that the unit was built for the type of gas you will be using, and that the gas inlet pressure is within the appropriate range.(Please refer to p.8.)
- Gas pressure below this specified range for the water heater and/or insufficient gas volume will adversely affect performance.
- Inlet gas pressure must not exceed the maximum values; gas pressure above the specified range will cause dangerous operating conditions and damage to the unit.
- Until testing of the main gas line supply pressure is completed, ensure the gas line to the water heater is disconnected to avoid any damage to the water heater.
- Always use approved connectors to connect the unit to the gas line. Always purge the gas line of any debris before connecting to the water heater.
- Install a manual gas shut-off valve between the water heater and the gas supply line.
- The regulator is preset at the factory. It is computer controlled and is not to be adjusted by any person other than a licensed professional.
- When the gas connections are completed, perform a gas leak test either by applying soapy water to all gas fittings and observing for bubbles or by using a gas leak detection device.



### WARNING

Conversion of this unit from natural gas to propane (LPG) or propane (LPG) to natural gas can not be done in the field. Contact your supplier to get the correct unit for your gas type.

## 4.8 MEASURING INLET GAS PRESSURE AND TESTING GAS LEAKAGE

- ①.Shut off the manual gas valve on the supply gas line.
- ②.Open a tap/outlet. The unit should turn on and the gas in the gas pipe line should be purged.
- ③.Leave the tap/outlet running until the unit shuts down due to lack of gas supply. Then turn off the tap/outlet.
- ④.Remove the screw on the pressure port located on the gas inlet of the water heater shown in the diagram to the above.
- ⑤.Connect the manometer to the pressure port.
- ⑥.Re-open the manual gas valve. Check to see that there are no gas leaks.
- ⑦.Open some of the fixtures that use a high flow rate to turn on the water heater.
- ⑧.Check the inlet gas pressure in the position showed in the red circle above When the water heater is at a maximum operation capacity, the inlet gas pressure point must be within the appropriate range.

*(Please refer to p.11)*

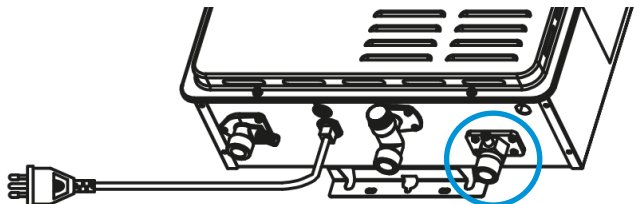

## 4.9 WATER CONNECTIONS

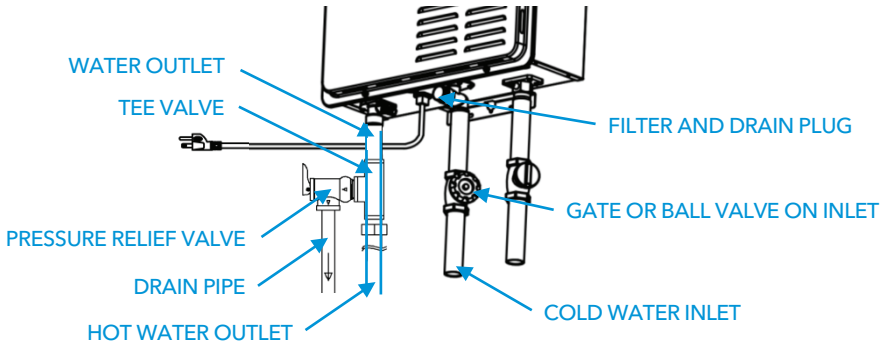

- All pipes, pipe fittings, valves and other components, including soldering materials, must be suitable for potable water systems.
- A manual shut off valve must be installed on the cold water inlet to the water heater between the main water supply line and the water heater.
- Only a gate valve or a ball valve is to be used on the cold water supply.
- Check the cold water pressure. If above 1000 kPa an approved limiting valve must be fitted.
- Before installing the water heater, flush the water line to remove all debris, and after installation is complete, purge the air from the line. Failure to do so may cause damage to the heater.
- To prevent water heater water system damage caused by excessive pressure. At the water outlet of the water heater, it is necessary to install an appropriate pressure relief valve to protect the water system and user safety. The pressure relief valve complies with ANSIZ21.22/CSA 4.4
- In the hot water system, the temperature rises continuously, and the volume of water expands.
- If the system is equipped with an expansion tank or a flexible connection bellows can absorb a part of the expansion amount, the expansion tank or the soft connection bellows cannot absorb the pressure relief valve needed to protect the pressure relief valve to protect The entire system prevents breakage of pipes and other components, so the relief valve pressure setting is generally selected to be slightly less than the maximum pressure ( $P_{max}$ ) that the entire system can withstand.
- In addition, the pressure can not be the same as the normal operating pressure.
- In order to prevent the damage of the temperature probe or control system and cause the continuous heating of hot water to reach  $100^{\circ}\text{C}$  ( $212^{\circ}\text{F}$ ) vaporization, it is necessary to install a temperature and pressure safety valve, and the temperature and pressure valve temperature reaches  $99^{\circ}\text{C}$  ( $210^{\circ}\text{F}$ ) to relieve the pressure, thereby protecting the entire system. So the safety valve temperature is generally set to  $99^{\circ}\text{C}$  ( $210^{\circ}\text{F}$ ).
- There is a wire mesh filter to discourage debris from entering your heater. Clean filter after initial installation to ensure no debris from the pipe work has clogged it.

## 4.10 PRESSURE RELIEF VALVE INSTALLATION AND ATTENTIONS

| Model | Recommended pressure relief value / temperature |
|-------|---|
| GA26O | 800kPa/99°C (201°F)                             |

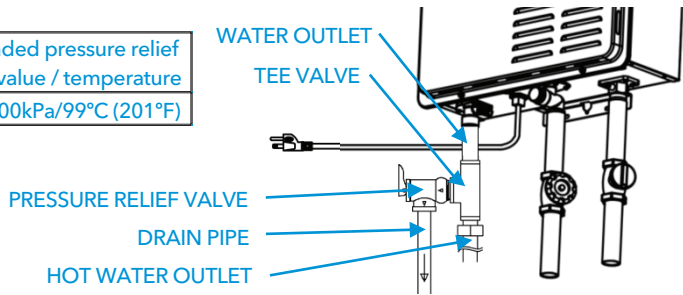

- Please use Teflon tape or sealant to seal the thread of pressure relief valve, then install it into Tee valve G3/4 outlet (As shown above).
- Please use Teflon tape or sealant to seal the thread of water outlet, then install pressure relief valve, tee valve and water outlet together. Please select a suitable position to install (As shown above).
- Please note that the outlet of pressure relief valve can not face upward, otherwise it will always leave some water inside.
- Anti-fouling and anti-scaling, dirt will directly affect the normal function of the safety valve function.
- The drain pipe must match the drain port to ensure that the valve does not interfere with the normal operation of the valve.
- The pressure relief valve outlet can be installed horizontally or vertically, but it cannot make pressure outlet facing upwards, otherwise it can not work normally. It is forbidden to block its outlet
- The dirt will directly affect the normal function of the safety valve function. It requires hot water system maintenance of anti-fouling and anti-scaling cleaning.
- The user must check the relief valve at least once a year. When checking, turn off the water heater's power supply and gas. Turn on the water inlet switch to create pressure in the water system. Then gently open relief valve handle until there is water out and then gently close, if there is no water out, indicating that the valve is invalid, this time should immediately turn off the water heater water switch and ask the service personnel to deal with.
- Before operating the handle, check the discharge line connecting the valve to ensure that the water drained from the valve can be drained to a suitable place.



### WARNING

- Do not check the safety valve when the water heater is in normal operation to avoid hot water burns.
- When the set temperature exceeds 50 °C, the flick mixer must be installed to mix the cold water and hot water before the temperature does not exceed 50 °C, otherwise it will burn the skin. Please refer to the method of using the flick mixer. *(Please refer to p.23~24)*

## 4.11 WIRING DIAGRAM

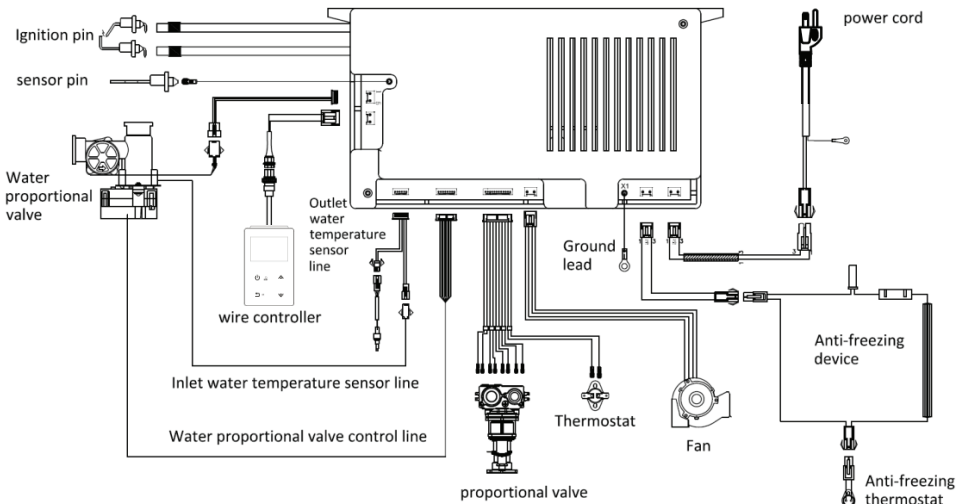

## WARNING

Do not reverse the hot outlet and cold supply line connections to the water heater as this will cause your heater to operate improperly.

## 4.12 ELECTRICAL CONNECTION

- The water heater must be electrically grounded. Do not attach the ground wire to either the gas or water piping.
- The water heater requires an AC 110V 60Hz.
- The weather-proof power point should be no more than 1 meter from the base of the water heater for easy access.
- Install a power switch so that the electrical power can be switched off if necessary.
- If the cord supplied with this appliance must be replaced, it must be replaced with the correct appliance wiring material supplied by the Manufacturer.
- When servicing or replacing parts within the water heater, label all wires prior to disconnection to facilitate an easy and error free reconnection. Verify proper operation after servicing.

## 4.13 HOT WATER HEATER AUTOMATIC DRAINAGE

- The water heater has an automatic drainage function. When the water inlet pressure of the water heater exceeds 1.0MPa~1.2MPa, the water heater will automatically drain and relieve pressure.
- Do not place objects around the water heater to avoid damage caused by water immersion when draining. The pressure relief valve is disassembled as shown below.

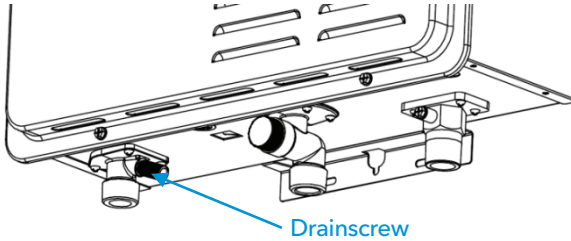

### WARNING

Conversion of this unit from natural gas to propane (LPG) or propane (LPG) to natural gas can not be done in the field. Contact your supplier to get the correct unit for your gas type.

## 4.14.CHECK THE WATER HEATER

After the installation of the water heater is completed, it is necessary to check that the water heater has no air leakage and water leakage, and the ignition operation is normal, and there is no fault alarm.



## 5. REMOTE CONTROLLER

- The water heater can be installed with up to three remote controllers. Each remote controller has two functions which can adjust the set temperature and indicate the error code.
- PRIORITY function: The controller that is activated first (i.e. button is pressed) is given PRIORITY function, and can freely adjust the temperature. Remaining controllers will display the set temperature however will not be able to make any adjustments. After a 15 minute period of inactivity the priority on the first remote will cease and priority can then be assigned to another remote by activating it (i.e. a button is pressed). Then the new controller has priority and the cycle repeats.
- Default setting temperature: At the initial power on, the setting temperature will be the same as the value set on DIP switch. After the initial use, it will remember the former setting temperature.
- All water heater models have self diagnostic function for safety and convenience when troubleshooting. If there is a problem with the installation or the unit, it will display a numerical error code on the remote controller (or the LED of the computer board will be blink.)

## REMOTE CONTROLLER INSTALLATION REQUIREMENTS

- The remote controllers are splash resistant, however should not be positioned where it can be splashed directly & should be appropriately sealed between the surface of the wall & controller.
- The remote controller can be installed in the bathroom provided it is correctly installed.

### Remote controllers output temperature setting (70°C mode)

- The remote controller is able to adjust the output temperature in the range of 95°F to 158°F in one degree increments.

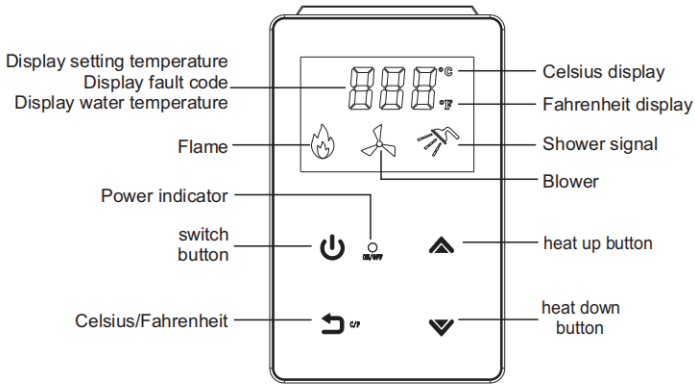

## 5.1 REMOTE CONTROLLER INSTALLATION

The remote controller comes with a 7.9m cable. If a longer cable is needed, please purchase a shielding line. Cut the original line and rewire according to the polarity to avoid short circuit whilst adhering to the requirements below:

- Minimum 18AWG wire
- Maximum run of 30m

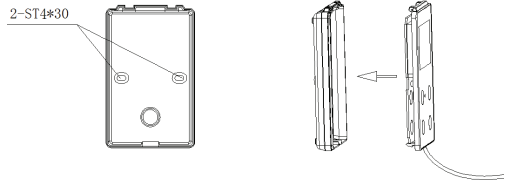

- Attach the remote control to the wall with screws supplied.



## WARNING

- DO NOT locate the remote controls where they may come into contact with water.
- DO NOT position the remote controls in the vicinity of chemicals.
- DO NOT position the remote controls over a heat generating appliance (i.e. cooker, toaster)
- DO NOT position the remote controls where materials may spill onto them.
- PLEASE NOTE IF THE CONTROLS ARE TO BE FITTED TO A METAL SURFACE AN INSULATION PLATE SHOULD BE PROVIDED BEHIND THE MOUNTING POSITION.

## 5.2 CONNECTION OF REMOTE CONTROLLER WIRING TO THE WATER HEATER

- ①. Turn off the power supply to the water heater.
- ②. Connect the first controller only and turn on the power supply to the water heater.
- ③. Turn off the first controller by pressing the on/off button (LED light will turn off).
- ④. Continue to connect any additional remote control wires to the remote terminals directly.
- ⑤. **DO NOT** jump or short-circuit wires otherwise the PCB may become damaged.
- ⑥. Return the front cover.

### **DO NOT TURN ON THE REMOTES UNTIL INSTRUCTED.**

- ⑦. Activate the first remote by pressing & holding the 'cool' (down arrow) button for 5 secs until a single beep sounds. Then press & hold the 'heat' (up arrow) button for 5 seconds until the LED screen lights up.
- ⑧. Adjust the on screen value to set the ID (available ID's include -0, -1, -2). Press the on/off button to confirm (The ID of the remote control cannot be repeated).
- ⑨. Repeat for all additional controllers.
- ⑩. Controllers can now be turned on and will operate as per the PRIORITY function. *(refer to p. 21)*

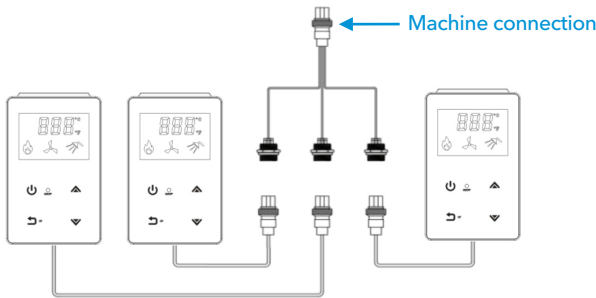

## 6. INITIAL OPERATION

### **FOR YOUR SAFETY, READ BEFORE OPERATING:**

- Check the **GAS** and **WATER CONNECTIONS** for leaks before startup for the first time.
- Open the main gas supply valve to the unit using only your hand to avoid any spark. Never use tools. If the knob will not turn by hand, do not try to force it. Forced repair may result in a fire or explosion due to gas leaks.
- Check the **GAS PRESSURE**. *(Refer to p.11)*
- Do not try to light the burner manually. It is equipped with an electronic ignition device which automatically lights the burner.
- Check for **PROPER VENTING** and **COMBUSTIBLE AIR** to the heater.
- Purge the **GAS** and **WATER LINES** to remove any air pockets.
- Do not use this water heater if any part has been submersed under water.



1. Once the above checks have been completed, please clean filter of any debris (refer to p.24).



2. Fully open the manual water control valve on the water supply line.



3. Open a hot water tap to verify that water is flowing to that tap.



4. Fully open the manual gas control valve installed.



5. Turn on the 110V 60Hz power supply to the water heater.



6. Now you are ready to enjoy hours of endless hot water.



## WARNING

- DO NOT SPRAY IN THE VICINITY OF THIS APPLIANCE WHILE IT IS IN OPERATION
- DO NOT USE OR STORE FLAMMABLE MATERIALS IN OR NEAR THIS APPLIANCE
- DO NOT PLACE ARTICLES ON OR AGAINST THIS APPLIANCE
- DO NOT MODIFY THIS APPLIANCE



## 7. NORMAL OPERATION

### STARTING STEPS:

- ①. Turn on the power switch.
- ②. After confirming power is on, press the remote control power button.
- ③. Open the inlet water valve and gas valves.
- ④. Open the water valve (hot water tap), the water heater will ignite and work, and hot water will flow out.
- ⑤. During the operation of the water heater, if the power supply suddenly stops, the water heater will stop working and close the gas valve. When the power is reset, the water heater with the remote control can be started by the remote control, and the water heater without the remote control can be started after re-opening the water.
- ⑥. Power failure before operation, the water heater can not start to provide hot water service.

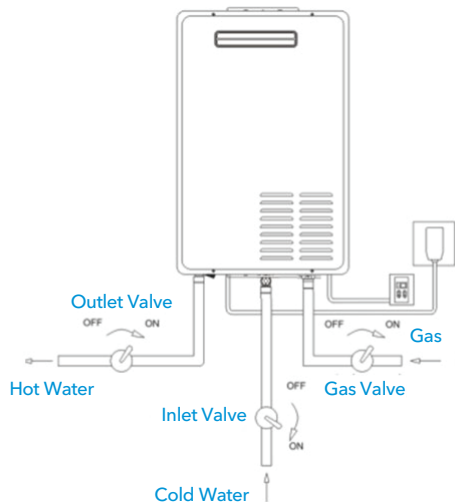



## 7.1 NORMAL OPERATION WITH MULTIPLE REMOTE CONTROLLERS INSTALLED

- Press the ON/OFF button. The Power light will become lit on the remote controller with setting temperature displayed on each of the remote controllers. The controller with priority function will have a flashing Power light.
- Set the required temperature using the Cool & Heat Buttons. (The temperature setting can only be changed by the priority controller. Refer to p. 21 for detail regarding the PRIORITY function).
- Open a hot water tap, and ensure the Burner ON light is lit. Mix cold water with the hot as required.
- Close the hot water tap. The Burner light will turn off.

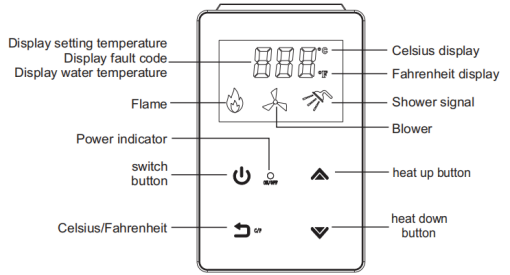

## 7.2 FREEZE PREVENTION



### WARNING

If freezing conditions are expected, turn off water and gas and drain all water from the appliance. If power and the automatic frost protection are connected, freezing will be prevented.

- Only the pipes and heat exchanger inside the water heater will be protected.
- Any hot or cold water pipes located outside of the unit will not be protected.
- Proper protection and insulation of these pipes will be required to ensure these are protected from freezing.

1. Turn Water Off
2. Turn Gas Off
3. Turn Off The Power Supply
4. Drain Water

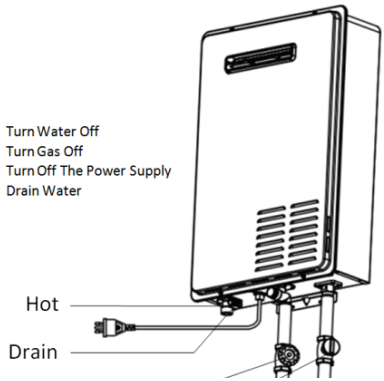

## 8. MAINTENANCE AND SERVICE

The water heater should be checked at least once a year or as necessary by a licensed technician. If repairs are needed, any repairs should be done by a licensed technician. The water heater's lifetime may be extended by regular maintenance.

The water heater should be checked at least once a year or as necessary by a licensed technician. If repairs are needed, any repairs should be done by a licensed technician. The water heater's lifetime may be extended by regular maintenance.



## WARNING

- Turn off the electrical power supply and close the manual gas control valve and the manual water control valve before servicing.
  - Label all wires prior to disconnection when servicing controls. Wiring errors can cause improper and dangerous operation.
  - Verify proper operation after servicing.
  - Should overheating occur or the gas supply fails to shut off, turn off the manual gas control valve to the appliance.
- 
- Clean the cold-water inlet filter.(Refer to diagram below).
  - Be sure that all openings for combustion air are not blocked. If blocked, remove obstruction.
  - Check that the opening for exhaust is not blocked. If blocked, shut off the water heater's combustion and then after a while, remove obstruction.
  - DO NOT touch while unit operating, otherwise you might get burnt due to high temperature.
  - Check the gas pressure.
  - Keep the area around the water heater clear. Remove any combustible materials, gasoline or any flammable vapors and liquids.

## 8.1 UNIT DRAINING AND FILTER CLEANING

- Close the manual gas shut off valve.
- Turn off the power supply to the water heater.
- Close the manual water shut off valve.
- Open all hot water taps in the house (Bathroom, kitchen, laundry, etc.). When the residual water flow has ceased, close all hot water taps.
- Have a bucket or container to catch the water from the unit's drain plugs. Unscrew the drain plugs to drain all the water out of the unit.
- Wait a few minutes to ensure all water has completely drained from unit.
- Clean the filter: Check the water filter located within the cold inlet. With a tiny brush, clean the water filter of any debris which may have accumulated and reinsert the filter back into the cold water inlet.
- Securely screw the drain plugs back into place. Hand- tighten only.

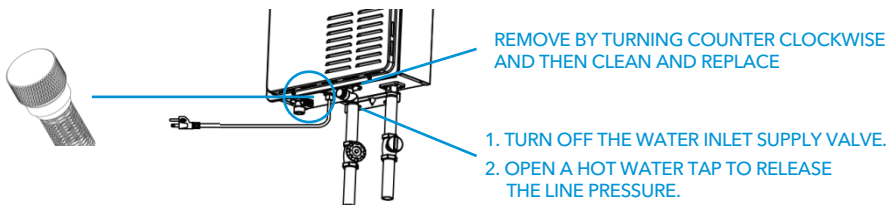

## 8.2 GENERAL TROUBLESHOOTING

| TEMPERATURE AND AMOUNT OF HOT WATER   |   |
|---|---|
| PROBLEM   | POSSIBLE SOLUTIONS  |
| The water is not hot enough.  | <ol style="list-style-type: none"> <li>1. Check cross plumbing between cold water lines and hot water lines.</li> <li>2. Is the gas supply valve fully open? (p.14)</li> <li>3. Is the gas line sized properly? (p.8)</li> <li>4. Is the gas supply pressure enough? (p.8)</li> <li>5. Is the set temperature set too low? (p. 20)</li> </ol>   |
| The water is too hot.   | Is the set temperature set too high? (p. 20)  |
| The hot water is not available when a fixture is opened.                        | <ol style="list-style-type: none"> <li>1. Make sure the unit has 110V 60Hz power supply</li> <li>2. If you are using the remote controller, is the power button turned on? (p. 23)</li> <li>3. Is the gas supply valve fully open? (p.14)</li> <li>4. Is the water supply valve fully open? (p.16)</li> <li>5. Is the filter on cold water inlet clean? (p. 24)</li> <li>6. Is there enough LPG in the bottle? (for propane)</li> </ol> |
| The hot water gets cold and stays cold  | <ol style="list-style-type: none"> <li>1. Is the flow rate enough to keep the water heater running?</li> <li>2. Is the gas supply valve fully open? (p.14)</li> <li>3. Is the filter on cold water inlet clean? (p. 24)</li> <li>4. Are the fixtures clean of debris and obstructions?</li> </ol>   |
| Fluctuation in hot water temperature.   | <ol style="list-style-type: none"> <li>1. Is the filter on cold water inlet clean? (p. 24)</li> <li>2. Is the gas line sized properly? (p.8)</li> <li>3. Is the supply gas pressure enough? (p.8)</li> <li>4. Check for cross connection between cold water lines and hot water lines</li> </ol>  |
| It takes a long time to get hot water at the fixtures.                          | 1. The time it takes to deliver hot water from the water heater to your fixtures depends on the length of piping between the two. The longer the distance or the larger the pipes, the longer it will take to get hot water.  |
| The Unit does not ignite when water goes through the unit.                      | <ol style="list-style-type: none"> <li>1. Check for the filter on cold water inlet. (p. 24)</li> <li>2. Check for reverse connection and cross connection.</li> <li>3. If you use the remote controller, is the power button turned on? (p. 23)</li> </ol>  |
| The fan motor is still spinning after operation has stopped.                    | 1. This is normal. After operation has stopped, the fan motor keeps running for 15 ~ 75 seconds in order to re-ignite quickly, as well as push all exhaust gas out of the flue.   |
| REMOTE CONTROLLER   |   |
| PROBLEM   | POSSIBLE SOLUTIONS  |
| Remote controller does not display anything when the power button is turned on. | <p>Press the ON/OFF button.<br/>If the light does not light up ?</p> <ol style="list-style-type: none"> <li>1. Make sure the unit has power supply.</li> <li>2. Make sure the connection to the unit is correct. (p.22)</li> </ol>  |
| An ERROR code is displayed.   | Please see the p.26   |
| Remote controller can not change the set temperature.                           | <p>Is power light flashing?<br/>If it is not, locate priority controller and turn off, or wait for 15 mins on inactivity</p>  |

## 8.3 PCB ERROR CODES

### TROUBLESHOOTING:

When the water heater fails, the display will display the fault code, while the buzzer will issue continuously "Beep" alarm sound, please follow the table to deal with accordingly.

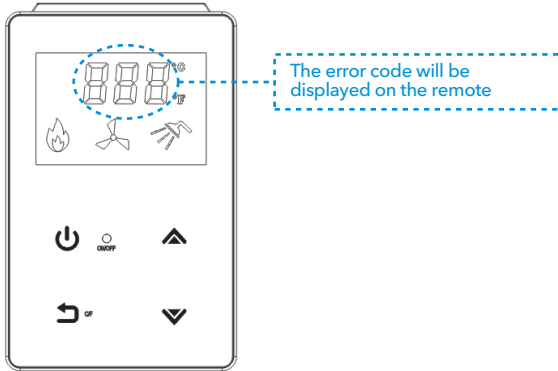





| ERROR CODE | FAULT DESCRIPTION AND HANDLING METHOD  |
|------------|--|
| E0         | Water temperature probe fault.   |
| E1         | Flame fault, Please check whether the gas supply is normal or not, confirm the gas is correctly connect and then use.                              |
| E2         | False fire fault.  |
| E3         | Thermostat protection.   |
| E4         | Water temperature probe fault.   |
| E5         | Fan fault, before the ignition, fan speed is detected for 8s less than 1000r/min or when burning fan speed for 6s less than 600r/min continuously. |
| E6         | Over -heating protection. Please check whether the water pressure is too low, confirm the water pressure is over starting pressure and then use.   |
| E7         | Solenoid valve fault.  |
| E8         | Flue jam fault.  |
| EN         | The set shutdown time has been reached.  |



If any codes like the above, if you check everything is normal, and if you restart the water heater but it cannot work normally, please notify the after-sales service staff at [customerservice@marey.com](mailto:customerservice@marey.com).

## THE FOLLOWING CONDITIONS ARE NOT A FAULT

| PHENOMENON   | REASON AND HANDLING METHOD  |
|--|---|
| Exhaust white smoke.   | Outdoor temperature is too low, the exhausted smoke encountered in the cold air and then condensing into a white mist.  |
| Flow rate of generated hot water is too small to achieve expected water temperature. | Hot water is too small to ignite the water heater, the water heater will turn off in the situation, then water will become cold. So please do not turn the hot water to be too small.   |
| Can't supply high temperature hot water in winter.                                   | The supply water temperature is very low and the water adjustment knob is already turned to be maximum, the setting temperature may be more than the heating capacity, then please adjust water supply to be smaller.   |
| Summer failed to supply low temperature hot water.                                   | Supply water temperature is too high, and the setting a low temperature but the inlet water is too small, it may cause the hot water temperature to be too high, then please adjust the amount of water properly more.  |
| After using 40 minutes the water heater suddenly flameouts.                          | In order to prevent hypoxia, some models have 40 minutes timer protection function, when you continuously use after 40 minutes will automatically turn off. Please turn off the tap after a while and then restart.   |
| Close the hot water valve, but the fan does not stop immediately.                    | This is the fan has a delay in the shutdown function, in order to completely clean the water heater exhaust to ensure the safety of users.  |
| Open the hot water valve, can't flow out hot water immediately.                      | It has a distance from the water heater to the hot water valve, because the water pipe has some cold water, it takes some time for the cold water to flow out and then comes the hot water. The farther the distance from the pipeline, the more time it takes to wait. |
| It always has some water out from drain valve.                                       | This is because the inlet water pressure is too high, drain valve will work to release the high pressure (p.17) try to reduce the inlet water pressure by turning down the gate valve or the ball valve (refer to 4.9) until water leakage stop.                        |

## 8.4 THE TEMPERATURE SETTING OF 70°C MODE

|   |      |
|---|------|
|  | 70°C |
|  | 65°C |
|  | 60°C |
|  | 55°C |

|   |      |
|---|------|
|  | 50°C |
|  | 45°C |
|  | 40°C |



### WARNING

1. Service Shall Be Carried Out Only By Authorized Personnel And The Appliance Shall Not Be Modified;
2. The Appliance Must Be Installed, Commissioned And Serviced By An Authorized Person In Accordance With The Requirements;
3. Warning: For Continued Safety Of This Appliance It Must Be Installed, Operated And Maintained In Accordance With The Manufacturer'S Instructions;



## 9. PACKING LIST

| NUMERICAL ORDER | DESIGNATION                                  | QUANTITY |
|-----------------|--|----------|
| 1               | Gas water heater                             | 1piece   |
| 2               | Instruction Manual (including warranty card) | 1piece   |
| 3               | Controller                                   | 1piece   |
| 4               | Expansion screw                              | 2piece   |
| 5               | Expansion rubber plug                        | 4piece   |
| 6               | Installing screws                            | 2piece   |
| 7               | Wooden screws                                | 2piece   |

Please feel free to contact us if you have any questions about our products, warranty service, or if you need assistance installing a unit. We also strive for continuous improvement, so we welcome your comments, feedback and suggestions.



**U.S.A**

**+1 (855) 627-3955**

**PUERTO RICO**

**(787) 727-0277**

**[customerservice@marey.com](mailto:customerservice@marey.com)**

**[www.Marey.com](http://www.Marey.com)**





